

LCD Display

1. Overview:

In this lesson, you will learn how to wire up and use an alphanumeric LCD display. The display has an LED backlight and can display two rows with up to 16 characters on each row. You can see the rectangles for each character on the display and the pixels that make up each character. The display is just white on blue and is intended for showing text.

In this lesson, we will run the Arduino example program for the LCDlibrary, but in the next lesson, we will get our display to show the temperature, using sensors.

2. Component Required:

- (1) x Uno R3
- (1) x LCD1602 module
- (1) x Potentiometer (10k)
- (1) x 830 tie-points Breadboard
- (16) x M-M wires (Male to Male jumper wires)



3. Component Introduction:

- **LCD1602**

Introduction to the pins of LCD1602:

VSS: A pin that connects to ground

VDD: A pin that connects to a +5V power supply

VO: A pin that adjust the contrast of LCD1602

RS: A register select pin that controls where in the LCD's memory you are writing data to. You can select either the data register, which holds what goes on the screen, or an instruction register, which is where the LCD's controller lookuonshun for instructions on what to do next.

R/W: A Read/Write pin that selects reading mode or writing mode

E: An enabling pin that, when supplied with low-level energy, causes the LDC module to execute relevant instructions.

D0-D7: Pins that read and writedata

A and K: Pins that control the LEDbacklight

4. Connection:

- Schematic

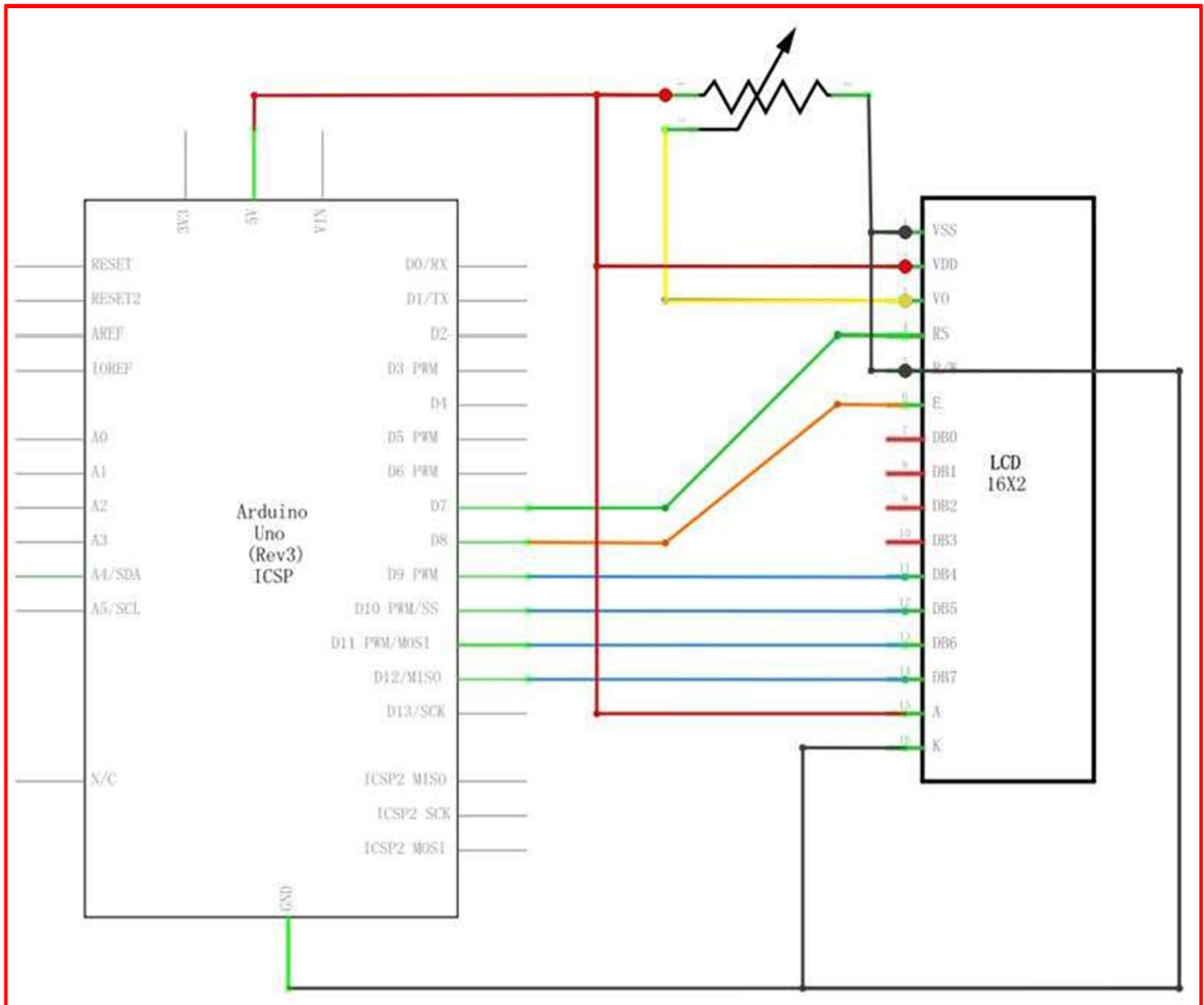

5. Wiring Diagram:

