

Stepper Motor

1. Overview:

In this lesson, you will learn a fun and easy way to drive a stepper motor. The stepper we are using comes with its own driver board making it easy to connect to our UNO.

2. Component Required:

- (1) x Uno R3
- (1) x 830 tie-points breadboard
- (1) x ULN2003 stepper motor driver module
- (1) x Stepper motor
- (6) x F-M wires (Female to Male DuPont wires)
- (1) x M-M wire (Male to Male jumper wire)

3. Component Introduction:

- **Stepper Motor**

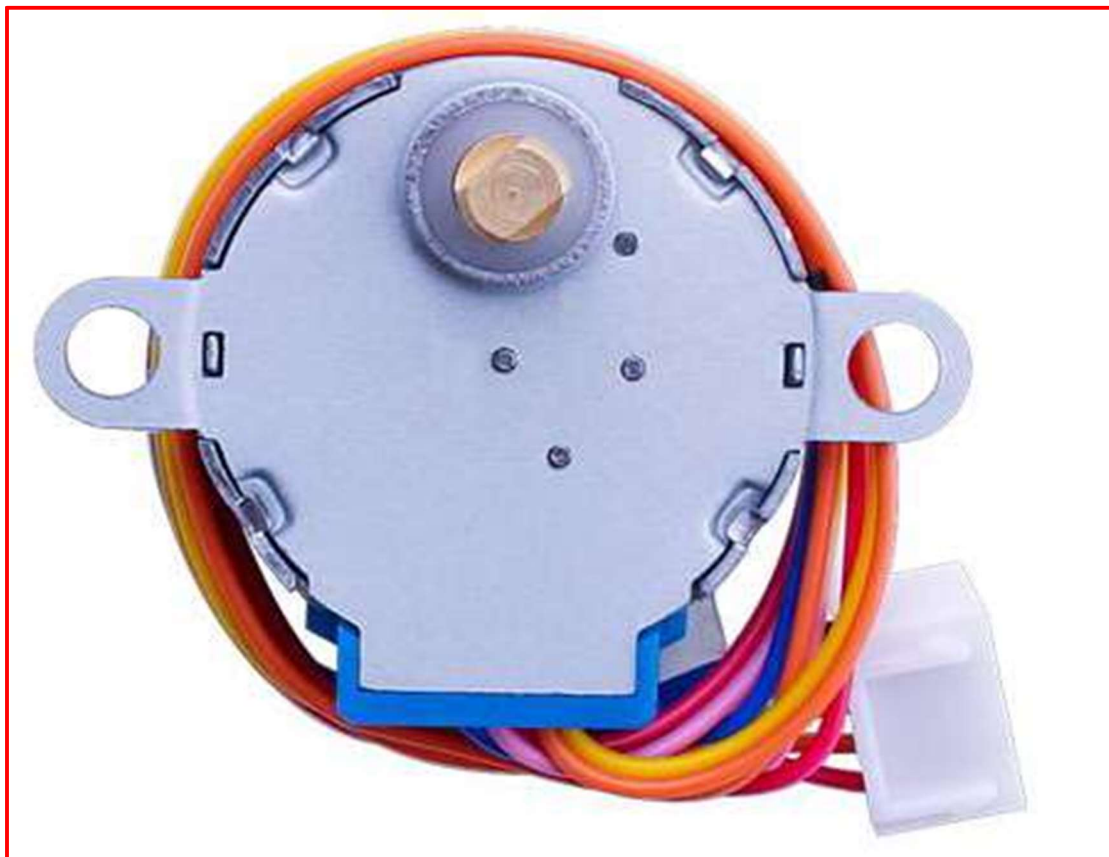



A stepper motor is an electromechanical device which converts electrical pulses into discrete mechanical movements. The shaft or spindle of a stepper motor rotates in discrete step increments when electrical command pulses are applied to it in the proper sequence. The motors rotation has several direct relationships to these applied input pulses. The sequence of the applied pulses is directly related to the direction of motor shafts rotation. The speed of the motor shafts rotation is directly related to the frequency of the input pulses and the length of rotation is directly related to the number of input pulses applied. One of the most significant advantages of a stepper motor is its ability to be accurately controlled in an open loop system. Open loop control means no feedback information about position is needed. This type of control eliminates the need for expensive sensing and feedback devices such as optical encoders. Your position is known simply by keeping track of the input step pulses.

- **Stepper motor 28BYJ-48 Parameters**

- Model: 28BYJ-48
- Rated voltage: 5VDC
- Number of Phase: 4
- Speed Variation Ratio: 1/64
- Stride Angle: 5.625° /64
- Frequency: 100Hz
- DC resistance: 50Ω±7%(25°C)

- Idle In-traction Frequency: > 600Hz
- Idle Out-traction Frequency: > 1000Hz
- In-traction Torque >34.3mN.m(120Hz)
- Self-positioning Torque >34.3mN.m
- Friction torque: 600-1200 gf.cm
- Pull in torque: 300 gf.cm
- Insulated resistance >10MΩ(500V)

- Insulated electricity power: 600VAC/1mA/1s
- Insulation grade: A
- Rise in Temperature <40K(120Hz)
- Noise <35dB(120Hz,No load,10cm)

- Interfacing circuits

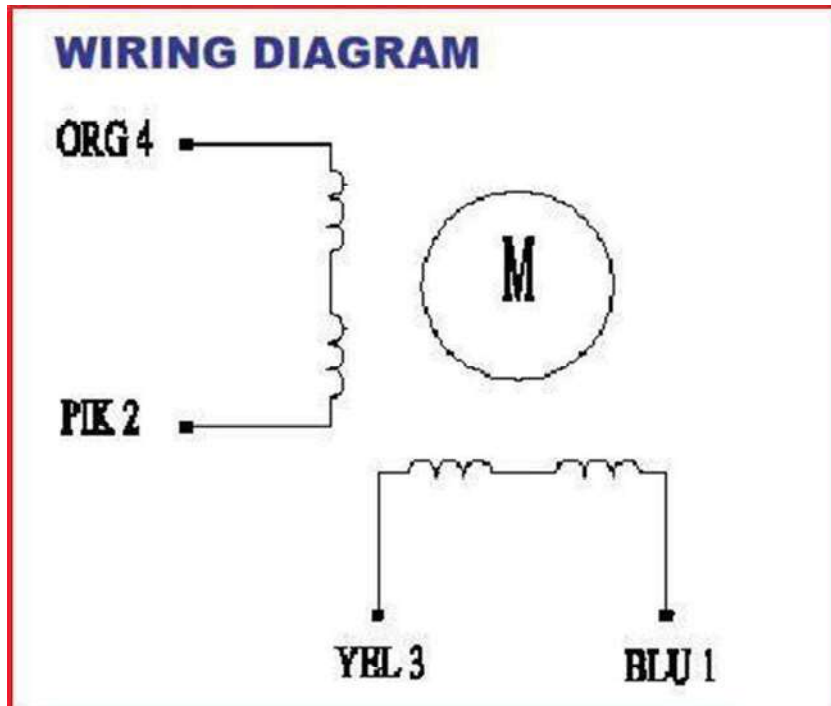

The bipolar stepper motor usually has four wires coming out of it. Unlike unipolar steppers, bipolar steppers have no common center connection. They have two independent sets of coils instead. You can distinguish them from unipolar steppers by measuring the resistance between the wires. You should find two pairs of wires with equal resistance. If you've got the leads of your meter connected to two wires that are not connected (i.e. not attached to the same coil), you should see infinite resistance (or no continuity).

- ULN2003 Driver Board

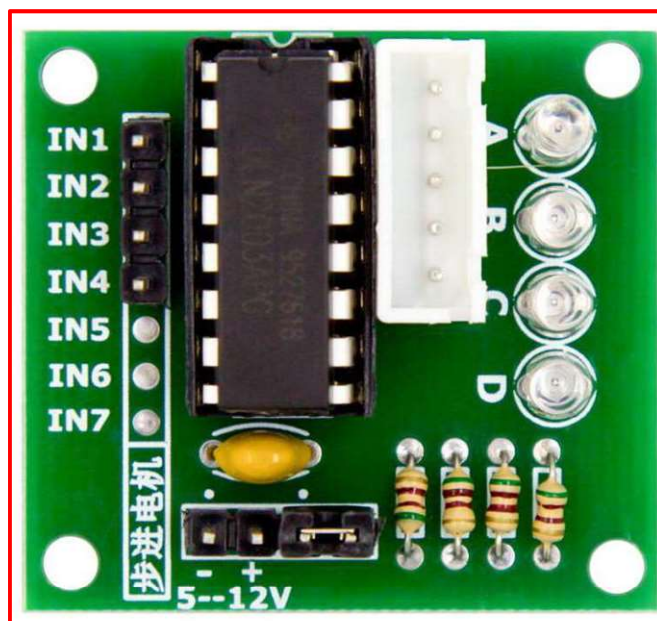

• Product Description

- Size: 42mmx30mm
- Use ULN2003 driver chip, 500mA
- A. B. C. D LED indicating the four phase stepper motor working condition.
- White jack is the four phase stepper motor standard jack.
- Power pins are separated
- We kept the rest pins of the ULN2003 chip for your further prototyping.

The simplest way of interfacing a unipolar stepper to Arduino is to use a breakout for ULN2003A transistor array chip. The ULN2003A contains seven Darlington transistor drivers and is somewhat like having seven TIP120 transistors all in one package. The ULN2003A can pass up to 500 mA per channel and has an internal voltage drop of about 1V when on. It also contains internal clamp diodes to dissipate voltage spikes when driving inductive loads. To control the stepper, apply voltage to each of the coils in a specific sequence.

The sequence would go likethis:

Lead Wire Color	---> CW Direction (1-2 Phase)							
	1	2	3	4	5	6	7	8
4 ORG	-	-						-
3 YEL		-	-	-				
2 PIK				-	-	-		
1 BLU						-	-	-

Here are schematics showing how to interface a unipolar stepper motor to four controller pins using a ULN2003A, and showing how to interface using four com

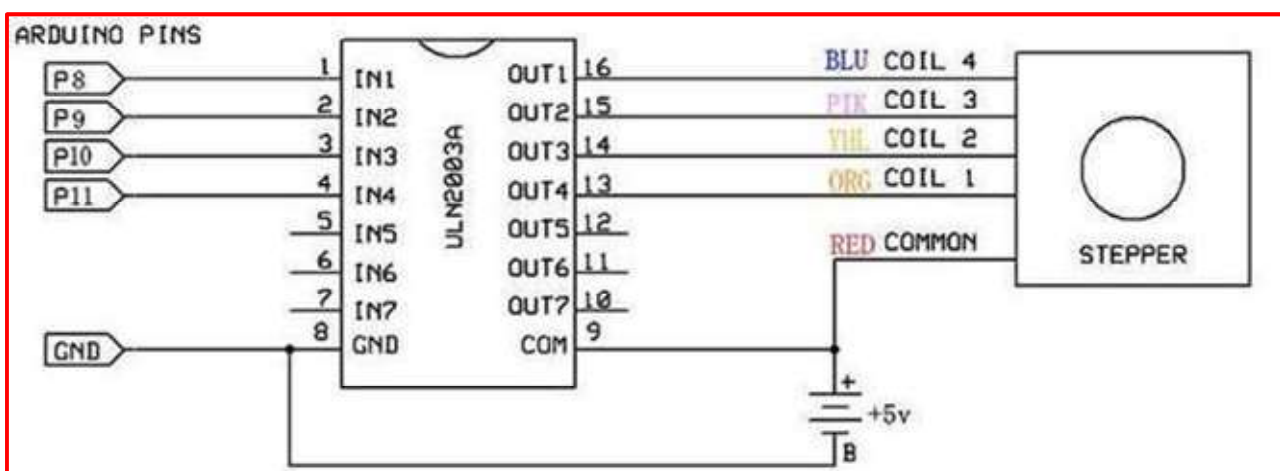

4. Connection:

- Schematic

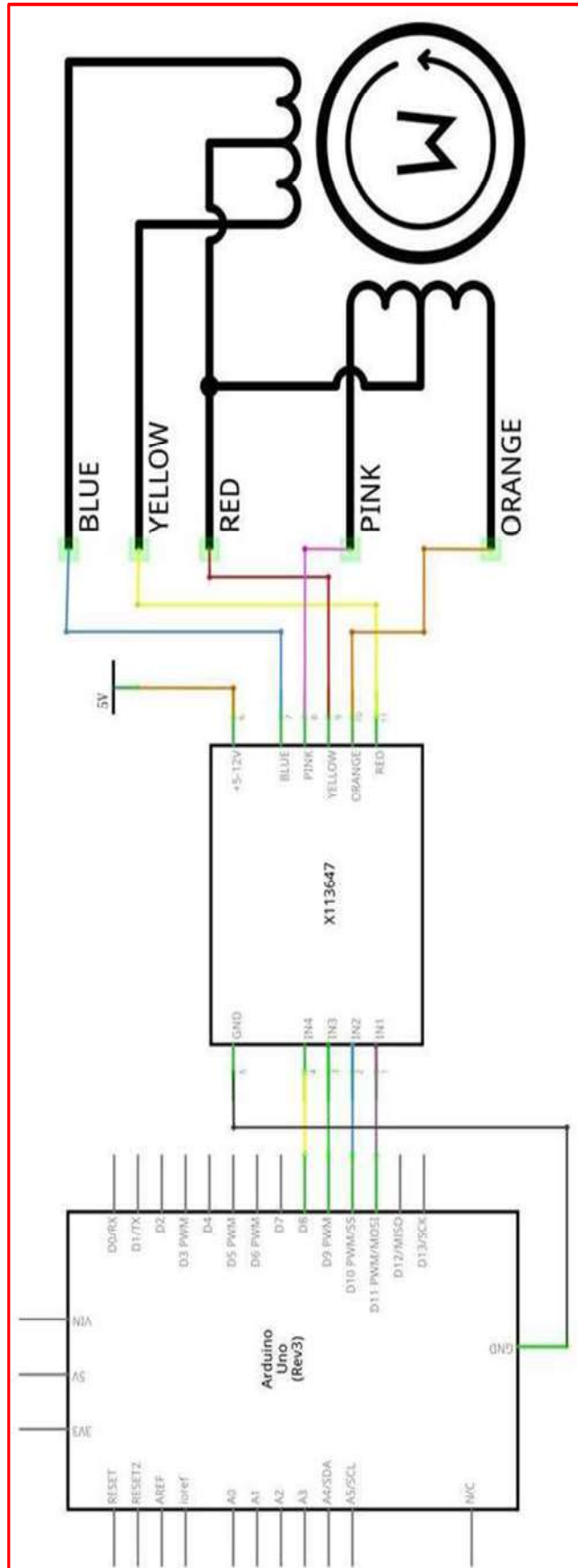

5. Wiring Diagram:

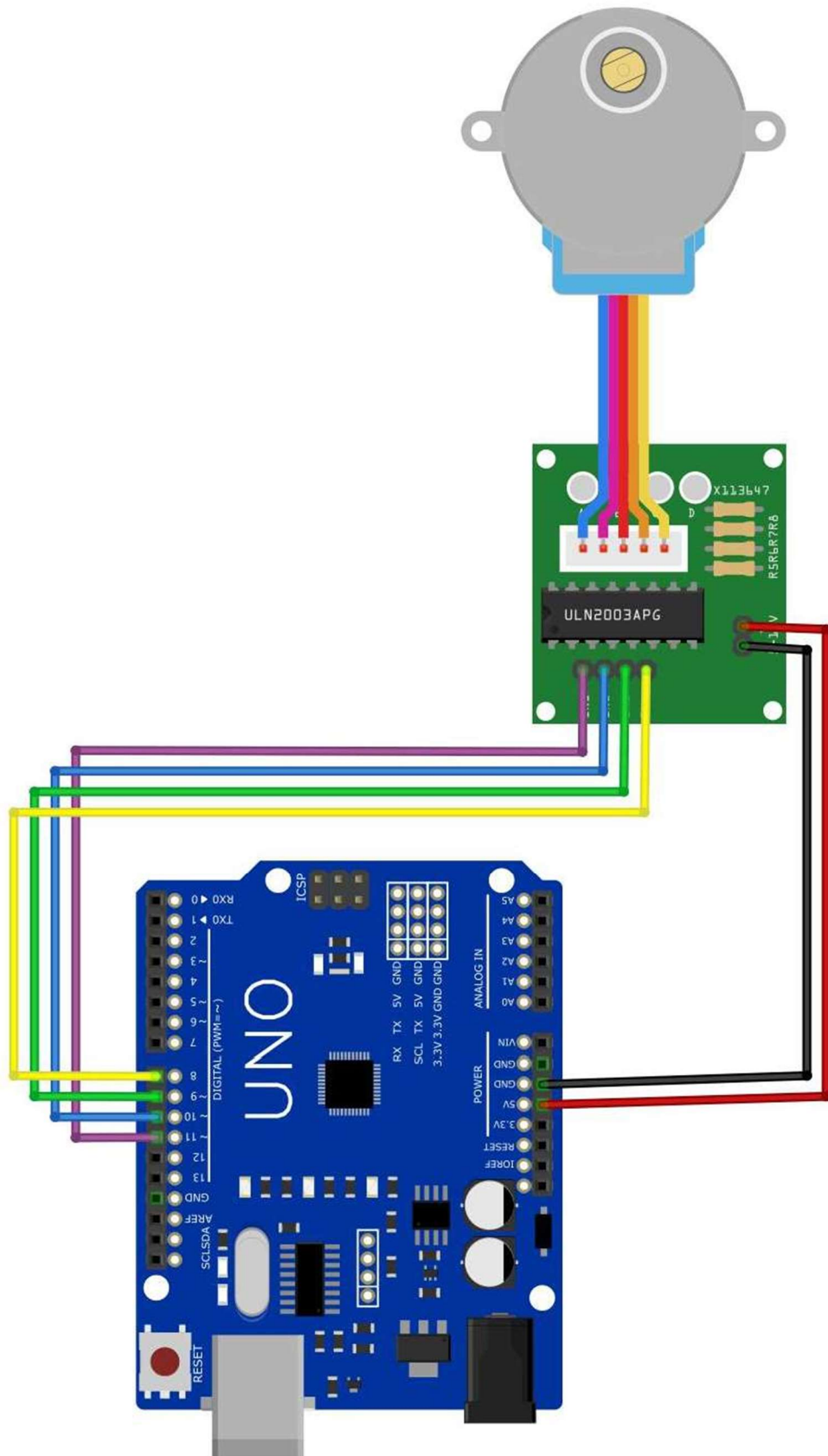



GeoTashfeen

We are using 4 pins to control the Stepper. Pin 8-11 are controlling the Stepper motor.

We connect the Ground from to UNO to the Stepper motor.